

JOURNAL OF THE AMERICAN CHEMICAL SOCIETY

Registered in U. S. Patent Office. © Copyright, 1967, by the American Chemical Society

VOLUME 89, NUMBER 25

DECEMBER 6, 1967

Physical and Inorganic Chemistry

The Solvation of the Hydrogen Ion by Water Molecules in the Gas Phase. Heats and Entropies of Solvation of Individual Reactions: $\text{H}^+(\text{H}_2\text{O})_{n-1} + \text{H}_2\text{O} \rightarrow \text{H}^+(\text{H}_2\text{O})_n$

P. Kebarle, S. K. Searles, A. Zolla, J. Scarborough, and M. Arshadi

Contribution from the Chemistry Department, University of Alberta, Edmonton, Alberta, Canada. Received July 5, 1967

Abstract: The hydrates $\text{H}^+(\text{H}_2\text{O})_n$ were observed in irradiated water vapor at pressures from 0.1 to 6 torr and temperatures from 15 to 600°. Determination of the relative concentrations of the hydrates after mass analysis of the ions allows determination of the equilibrium constants $K_{n-1,n}$ for the reactions $\text{H}^+(\text{H}_2\text{O})_{n-1} + \text{H}_2\text{O} \rightleftharpoons \text{H}^+(\text{H}_2\text{O})_n$. Determination of the equilibrium constants over the experimental range leads to values for $\Delta H_{n-1,n}$, $\Delta G^\circ_{n-1,n}$, and $\Delta S^\circ_{n-1,n}$. The experimental values for $-\Delta H_{n-1,n}$ and $-\Delta G^\circ_{n-1,n}$ in brackets, are: (1,2) 36 [25]; (2,3) 22.3 [13.6]; (3,4) 17 [8.5]; (4,5) 15.3 [5.5]; (5,6) 13 [3.9]; (6,7) 11.7 [2.8]; (7,8) 10.3 [2.2] kcal/mole. The free-energy data are for 300°K and standard state of 1 atm. From these data one can calculate the hydrate distribution over a wide range of pressures and temperatures. It is shown that the ΔH and ΔS values are of reasonable magnitude. The continuous decrease of the $\Delta H_{n-1,n}$ and $\Delta G_{n-1,n}$ values shows that the stabilities of the hydrates $\text{H}^+(\text{H}_2\text{O})_n$ change quite continuously. No single structure shows dominant stability. Comparison of the data with the proton affinity of water suggests that in the lower hydrates ($n = 2$ to 4 or even 6) all water molecules are equivalent. This would make the notation $\text{H}_3\text{O}^+(\text{H}_2\text{O})_n$ inappropriate. The data also indicate that beyond $n = 4$ either a new "shell" is started or crowding of the first "shell" occurs.

The interaction of ions with solvent molecules has been studied for many years in liquid solutions. Starting a few years ago we have published work¹⁻⁴ in which a new approach is used, namely, the study of ion-solvent interactions in the gas phase. This method has the special advantage of studying ion-solvent molecule complexes (ions surrounded by a cluster of solvent molecules) without the interference of the bulk of the solvent. The studies are thus specially suited to provide information on the interactions between the central ion and the solvent molecules in the incomplete or complete first and second solvation shells.

The gas-phase studies are based on mass spectrometric measurement of the relative concentrations of

ionic species A^+S_n or B^-S_n , where A^+ and B^- are any positive and negative ions and S is a solvent molecule. Several types of solvation studies can be undertaken if the relative concentrations of the ionic species are known. For example, enthalpies and entropies of individual solvent molecule addition steps can be obtained. The ion A^+ is produced in the gas phase by some form of ionizing radiation or thermal means. If the atmosphere surrounding the ion contains the vapor of a polar molecule (solvent S), a number of clustering reactions will occur.

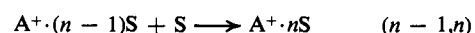
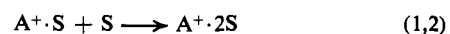

At equilibrium the following relations will hold

$$\Delta G^\circ_{0,n} = \Delta G^\circ_{0,1} + \Delta G^\circ_{1,2} + \dots + \Delta G^\circ_{n-1,n} \quad (\text{I})$$

- (1) P. Kebarle and A. M. Hogg, *J. Chem. Phys.*, **42**, 798 (1965).
- (2) A. M. Hogg and P. Kebarle, *ibid.*, **43**, 449 (1965).
- (3) A. M. Hogg, R. M. Haynes, and P. Kebarle, *J. Am. Chem. Soc.*, **88**, 28 (1966).
- (4) P. Kebarle in "Applications of Mass Spectrometry in Inorganic Chemistry," *Advances in Chemistry Series*, American Chemical Society, Washington, D. C., in press.

$$\Delta G^\circ_{n-1,n} = -RT \ln \frac{P_{A^+ \cdot nS}}{P_{A^+} \cdot (n-1)S P_S} = -RT \ln K_{(n-1),n} \quad (\text{II})$$

where P_X is the partial pressure of X.

Thus knowledge of the equilibrium concentrations of the clustered species $A^+ \cdot nS$ obtained from experiments at different pressures and temperatures will allow the determination of $K_{n-1,n}$ and will lead to the evaluation of $\Delta H_{n-1,n}$ and $\Delta S_{n-1,n}$. In the mass spectrometer experiments, the ratio of the partial pressures of the two ions (eq II) is replaced by the ratio of the ion intensities of the corresponding ions which are detected by bleeding a sample of the gas into an accelerating and mass analysis system. Studies of the system $\text{NH}_4^+(\text{NH}_3)_n^3$ and $\text{H}^+(\text{H}_2\text{O})_n^1$ based on the above considerations have been published.

The note on the water system¹ was the first attempt to obtain hydration step enthalpies $\Delta H_{n-1,n}$ with the mass spectrometric method. It was pointed out then, that the study was only tentative and preliminary. For example, no tests of the equilibrium condition (eq II) were made since the experiments were done at a single water pressure. Also, because of the limited temperature range covered, only three enthalpy values, $\Delta H_{4,5} = -20 \pm 5$, $\Delta H_{5,6} = -24 \pm 5$, and $\Delta H_{6,7} = -13 \pm 3$ kcal/mole, were obtained. Since considerable advances in technique and concepts about the experimental conditions were made after this early work, we felt that we should obtain a more complete and reliable set of $\Delta H_{n-1,n}$ and $\Delta S_{n-1,n}$ values for the very important water system.

The two major primary ions produced by the irradiation of water vapor by electrons, protons, or α particles are H_2O^+ and OH^+ . It was shown in 1940 by Tate, *et al.*,⁵ and later by Lampe, Field, and Franklin⁶ that these two ions react very rapidly with water to yield H_3O^+ . The hydronium ion so formed attaches water molecules according to the scheme 1, n . Since the reactions are exothermic, third bodies would be required for deactivation.

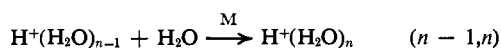
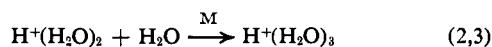
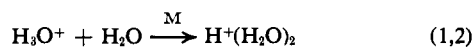

We write in the above equations $\text{H}^+(\text{H}_2\text{O})_2$ instead of $\text{H}_3\text{O}^+\text{H}_2\text{O}$ since previous work on the competitive solvation of the hydrogen ion by water and methanol and the present results, as will be shown later, indicate that the proton in small clusters is equally strongly bonded to each of the surrounding water molecules.

Experimental Section

α -Particle Mass Spectrometer. The experiments were done with two instruments. One of these is the α -particle mass spectrometer which has been described previously.^{2,7} It consists of a field free ion source which is irradiated by an uncollimated or partially collimated α -particle beam. Part of the gas is allowed to bleed through a leak into a vacuum chamber where the neutral molecules

(5) M. M. Mann, A. Hustralid, and J. T. Tate, *Phys. Rev.*, **58**, 340 (1940).

(6) F. W. Lampe, F. W. Field, and J. L. Franklin, *J. Am. Chem. Soc.*, **79**, 6132 (1957).

(7) P. Kebarle, R. M. Haynes, and S. K. Searles, *Advances in Chemistry Series*, No. 58, American Chemical Society, Washington, D. C., 1966, p 210.

are pumped out, while the ions are captured by electric fields, focused, and then magnetically mass analyzed.

The residence time of the average ion sampled from the ion source is a few milliseconds.⁷ The residence time of the ions can be increased by screening the region above the leak from the α beam. Screening a portion of about 1–2 mm above the leak increases the average residence time to more than 10 msec.⁷ Increases of the residence time represent tests for the equilibrium assumption. This test was applied to the water system, and it was found that the relative ion intensities remained constant with change of the residence time.

All runs with the α -particle instrument were done with gas flowing through the ion source. For this purpose the ion source was provided with an inlet and outlet tube. The inlet tube as well as the gas-handling plant were thermostated to the temperature of the ion source. The linear flow velocity through the ion source was approximately 20 cm/sec, which corresponds to a gas residence time in the irradiated volume of about 0.1 sec. Thus the flow does not affect the ion residence time which is much shorter. The flow is used to provide gas mixing, scavenging of impurities out of the ion source, and constant water pressure in the ion source. For partial pressures of water vapor between 0.1 and –1 torr, 5 torr of Ar carrier gas was used. The carrier gas was used since the intensity of the detected ion current becomes very low for ion source pressures less than 1 torr. Primary ionization of the carrier is passed on by charge transfer to the water molecules. Water vapor was supplied to the flow system by means of a small bulb containing liquid water. The bulb was connected by a capillary to the flow system. The flow through the capillary was regulated by temperature control of the liquid water. The partial pressure of water in the carrier gas was determined by measuring the weight loss of the bulb. It was assumed that the water vapor carried by the argon had the same volume per second of flow as the pure argon. The rate of flow of argon was measured with a flow meter.

The pressure in the ion source was measured directly with a capacitance torr meter.

Proton Beam Mass Spectrometer. The polonium source of the α particle spectrometer is an integral part of the ionization chamber.^{2,7} This does not permit experiments to be carried out above about 150° since above this temperature spreading of the polonium becomes rapid. For this reason experiments from 20 to 630° ion source temperatures were carried out in a proton beam mass spectrometer designed for ion molecule reactions at pressures up to 10 torr.^{8,9} The 100-kev beam produced by a Texas Nuclear Corp. proton generator was collimated before being allowed to impinge on the ion source. A schematic representation of the ion source and the accelerating electrodes is shown in Figure 1. The ion acceleration electrode system is essentially the conventional Nier arrangement. However, the first electrode is placed 7 mm below the ion source to allow more efficient pumping of the gas escaping from the ion exit slit. Build-up of the gas in the region between the ion source and this electrode induces collisional stripping of water molecules from the ion clusters. This effect was observed with the regular Nier geometry and was removed by spacing out the electrodes and reducing the ion exit slit to dimensions of $5 \times 4000 \mu$. The slit, which should not be thick compared with its width, lost too many ions are lost in it, was made from two stainless razor blade edges which were spot welded to a suitably slotted electrode. The alignment of the razor blade slit was done under a microscope. Even with the present arrangement partial stripping of the clusters leading to detectable lower hydrates was found to occur at pressures above 5 torr.

The ion source was mounted in an 8-in. diameter pipe connected to a 6-in. pumping system. This gave a pumping speed in the region of the ion source of 400 l./sec (air). The pumping speed for water vapor was increased roughly fivefold by cooling the vapor chevron baffle, incorporated in the pumping system, with liquid nitrogen. The pressure in the ion source was measured directly with a McLeod gauge. The distance between the proton beam and the ion exit slit is 6 mm and the ion source is field free.

Temperature Control of the Ion Sources. In order to obtain even temperature distribution on the insides of the ion source walls, both the α particle and proton beam sources were constructed from solid stainless blocks. The temperature, measured with iron-constantan thermocouples placed at two positions of the ion source(s), was found to agree within a few degrees even at the highest

(8) J. G. Collins and P. Kebarle, *J. Chem. Phys.*, **46**, 1082 (1967).

(9) J. G. Collins, Ph.D. Thesis, University of Alberta, Edmonton, Alberta, Canada.

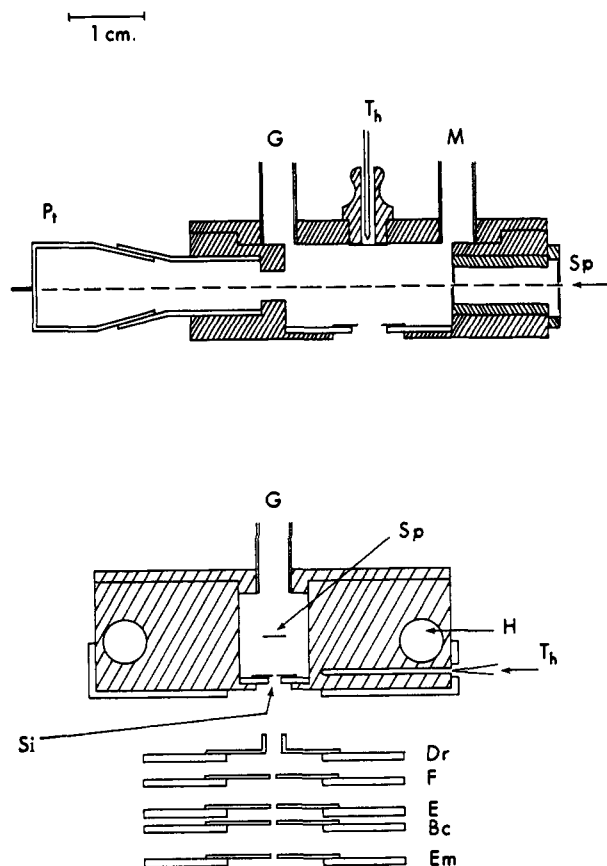

Figure 1. Front (upper) and side (lower) views of 100-keV proton beam ion source: G, gas inlet; T_h , thermocouple; M, to manometer; P_t , proton trap; S_p , proton entrance slit, 15μ wide; S_i , ion exit slit, 5μ wide; H, heater. Electrodes: Dr, draw out; F, focus half-plates; E, beam-defining slit; Bc, beam center half-plates; Em, entrance slits into magnetic mass analyzer.

temperatures used. Nevertheless the critical region around the ion exit slit could have been at somewhat lower temperature. The major heat loss being through radiation, an improvement could be obtained by heating the first electrode below the ion source to the temperature of the ion source. Such an arrangement is presently under construction.

Flow through the Ion Exit Leak. Measurements were made only at conditions where the mean free path for ion cluster-water molecule collisions was bigger than the dimension of the leak. Assuming a cross section of 50 \AA^2 for such a collision, the maximum pressure with a leak of $10\text{-}\mu$ diameter should be 6 torr. Experiments with different size leaks were made on the α -particle instrument. Slit leaks, single pinhole leaks, and multiple circular leaks (laser beam produced)³ were employed. It was found in all cases that, when the diameter of the hole or the width of the slit exceeded 10μ , nonequilibrium shifts of the cluster population toward higher mass occurred at pressures above 5–10 torr.

Conversely, the relative cluster distributions remained constant when the leaks were made smaller than a critical dimension. Therefore, we believe that our results are unaffected by condensation due to cooling by adiabatic expansion outside the ion source.

Results and Discussion

Some representative equilibrium constants $K_{n-1,n}$ are shown in Figure 2. Aside from experimental scatter the values of the equilibrium constants are seen to remain unchanged for a pressure increase by a factor of 50. The α -particle mass spectrometer values in the range 0.1–1 torr were obtained in the presence of argon as carrier gas (total pressure 5 torr, see Experimental Section). The presence of argon decreases the diffusion coefficient and thus increases the lifetime of the

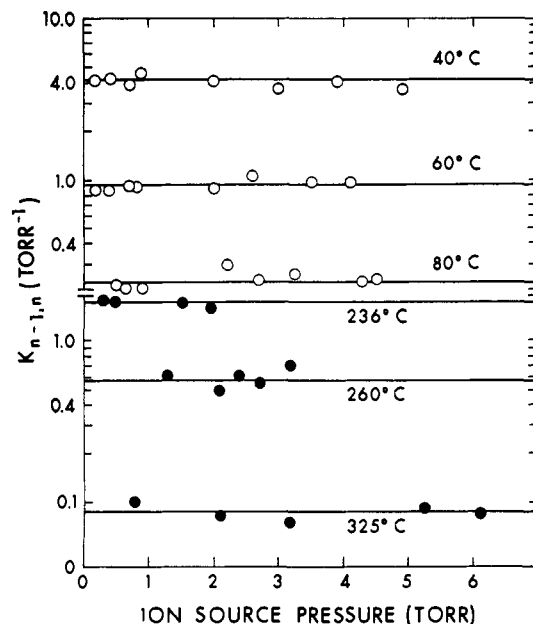

Figure 2. Plot of some representative equilibrium constants $K_{n-1,n}$ for the reaction $H^+(H_2O)_{n-1,n} + H_2O \rightleftharpoons H^+(H_2O)_n$ with water pressure: \circ , $K_{4,5}$ obtained with α -particle mass spectrometer; \bullet , $K_{2,3}$ obtained with proton mass spectrometer.

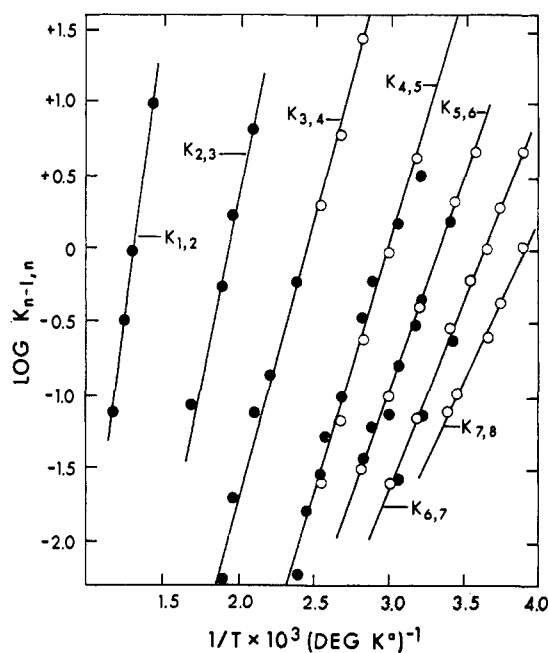

Figure 3. van't Hoff-type plots of equilibrium constants: \circ , α -particle mass spectrometer; \bullet , proton mass spectrometer.

ions.⁷ Agreement of data with and without argon is a confirmation of the equilibrium assumption.

van't Hoff-type plots of the equilibrium constants are shown in Figure 3. The data obtained on the proton and α -particle instruments are seen to be in good agreement. Since the two instruments have radically different gas-handling plants, ion sources, ion-focusing, and detection systems, agreement of the results is seen as mutual confirmation of the data. In Figures 4 and 5 plots are given for the change of $\Delta H_{n-1,n}$ and $\Delta G_{n-1,n}^\circ$ with n . The thermodynamic values are also summarized in Table I.

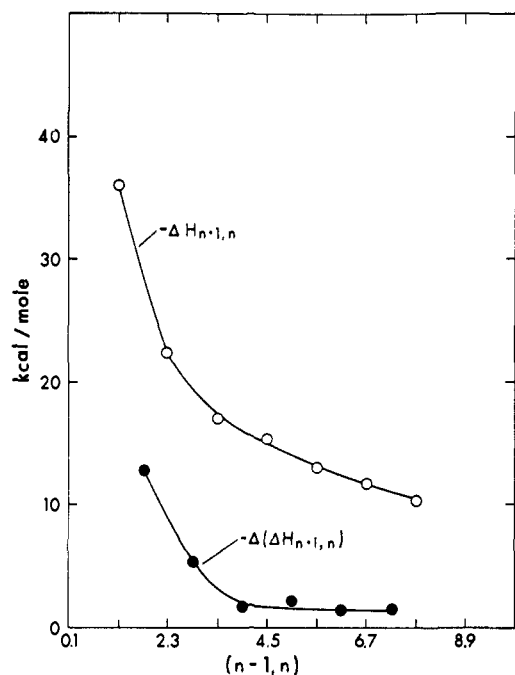

Figure 4. Plot of $\Delta H_{n-1,n}$ and $\Delta(\Delta H_{n-1,n})$ vs. $n-1,n$. The enthalpies of the reactions decrease quite regularly. A possible break is indicated between $\Delta H_{3,4}$ and $\Delta H_{4,5}$. As explained in text, this might be due either to a transition into a new "shell" or crowding of the old "shell."

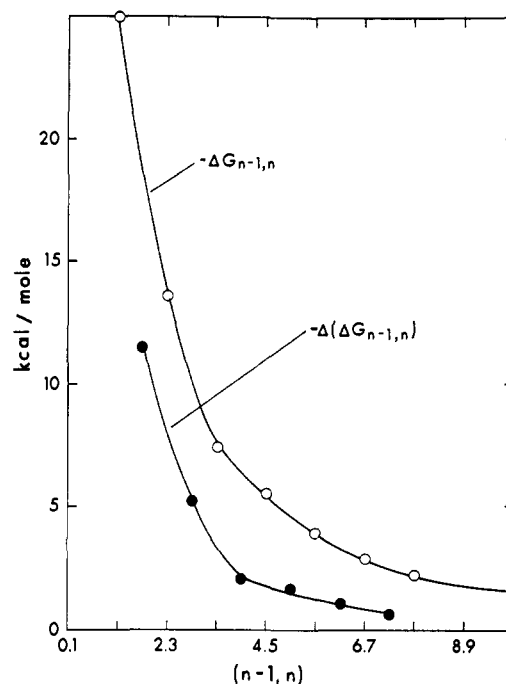
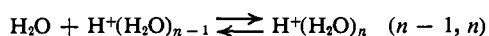

Figure 5. Plot of $\Delta G_{n-1,n}^\circ$ and $\Delta(\Delta G_{n-1,n}^\circ)$ at 300°K vs. $n-1,n$. Standard state of water vapor is 1 atm. Decrease of free-energy changes is quite regular showing that stabilities of clusters change quite regularly. A possible break is indicated between 3,4 and 4,5. This could be due either to crowding in the first "shell" or transition to an outer "shell."

Table I. Experimental Thermodynamic Values for the Gas-Phase Reactions



$n-1, n$	$-\Delta H_{n-1, n}$ kcal/mole	$-\Delta G_{n-1, n}^\circ$ kcal/mole	$-\Delta S_s^\circ$ eu	A^c	B^c
0,1	165 ^b
1,2	36	25	33.3	7.41	9.55
2,3	22.3	13.6	29	4.76	9.05
3,4	17	8.5	28.3	3.63	8.86
4,5	15.3	5.5	32.6	3.33	10.00
5,6	13	3.9	30.3	2.84	9.46
6,7	11.7	2.8	29.6	2.53	9.24
7,8	10.3	2.2	27	2.17	8.50

^a At 300°K, standard state of water, 1 atm. ^b From ref 13. ^c Constants for the equation $\log(K_{n-1,n}) = (A/T) \times 10^3 - B$. Data for water pressure in torr.

The data contained in Figure 3 and Table I allow one to determine the relative concentrations of the hydrates over a very wide range of temperatures and water pressures. Examples of such relative concentration plots are given in Figure 6, where calculated hydrate distributions are shown for the temperatures of 300 and 400°K. The relative equilibrium concentrations of the hydrates may be of interest in a number of situations. For example, in the radiolysis of water vapor the products of the ionic recombination reactions may depend on the size of the ion clusters (see Anderson, *et al.*¹⁰).

The plots in Figure 6 show a characteristic behavior. At low pressures where the low hydrates are present, the difference between the stability (free energy) of the hydrates is large. Under these conditions the con-

(10) A. R. Anderson, B. Knight, and J. Winter, *Nature*, 209, 199 (1966).

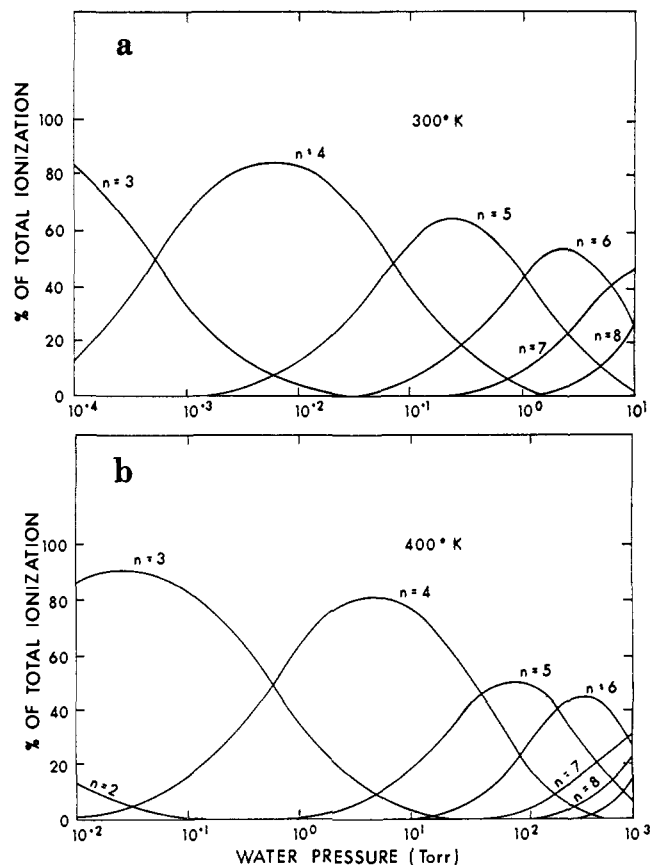

Figure 6. Equilibrium distributions of clusters $\text{H}^+(\text{H}_2\text{O})_n$ predicted by experimental data; logarithmic scale used for water partial pressure in order to accommodate a wide pressure range: (a) 300°K, (b) 400°K. Distributions at other temperatures can be simply calculated from data in Table I.

centrations of one or two hydrates are dominant. At higher pressures where the higher hydrates become stable, differences between the free energies of the hydrates are small and a number of hydrates are present simultaneously.

The calculated hydrate distributions were obtained by the following simple procedure. A set of equilibrium constants was calculated by substituting the desired constant temperature T in the straight-line relationships (Table I)

$$\log K_{n-1,n} = \frac{A \times 10^3}{T} - B$$

The concentration of H_3O^+ was then arbitrarily set equal to unity. The concentration of the species $\text{H}^+(\text{H}_2\text{O})_n$ was obtained with use of the equation $\log [\text{H}^+(\text{H}_2\text{O})_n] = \log K_{12} + \log K_{2,3} + \dots + \log K_{n-1,n} + (n-1) \log P$, where P is the partial pressure of water in torr. Setting the sum of the concentrations equal to 100, one obtains the relative concentrations in per cent of the total.

We now consider whether the observed enthalpy and entropy changes are of the right order of magnitude. To compare the experimental enthalpies, $\Delta H_{n-1,n}$, with the total enthalpy of solvation of the gaseous proton in liquid water, $\Delta H_{\text{sol}}(\text{H}^+(\text{g})) = -261$ kcal/mole,^{11,12} we take as initial state 1 mole of gaseous protons, which are assumed at low pressure such that the electrostatic repulsion between them is negligible, and a large quantity of liquid water. We evaporate successively moles of water and add them to the protons. The enthalpy change in such a single step is $\Delta H_{n-1,n} + \Delta H_{\text{evap}}(\text{H}_2\text{O})$. Since our data extends up to $\Delta H_{7,8}$, we evaporate 8 moles of water arriving at $\text{H}^+(\text{H}_2\text{O})_8$. The enthalpy change for this process is given by

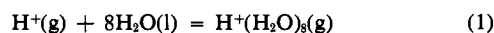

$$\Delta H_1 = \Delta H_{0,8} + 8\Delta H_{\text{evap}}(\text{H}_2\text{O})$$

where $\Delta H_{0,8} = \Delta H_{0,1} + \Delta H_{1,2} + \dots + \Delta H_{7,8}$. $\Delta H_{0,1}$ is the proton affinity of water, but with a negative sign. Taking for this step the literature value¹³ $\Delta H_{0,1} \pm -170$ kcal/mole and for the heat of evaporation of water $\Delta H_{\text{evap}} = +10.4$ kcal/mole, we obtain $\Delta H_1 = -213$ kcal/mole. Subtracting this value from the total heat of solvation of the proton $\Delta H_{\text{sol}}(\text{H}^+(\text{g})) = -261$ kcal/mole, we are left with $-261 - (-213) = -48$ kcal/mole = $\Delta H_{\text{sol}}(\text{H}^+(\text{H}_2\text{O})_8(\text{g}))$, which is the enthalpy of solvation of $\text{H}^+(\text{H}_2\text{O})_8(\text{g})$ into liquid water. An estimate of this enthalpy of solvation can be obtained with help of the Born equation.^{14,15} Assuming that the radius of the eight cluster is 4 Å, one obtains $\Delta H_{\text{sol}}(\text{H}^+(\text{H}_2\text{O})_8(\text{g})) = -40$ kcal/mole, while a radius of 5 Å leads to -33 kcal/mole. Since without a knowledge of the structure of the octahydrate a "correct" radius cannot be chosen (the radius of water molecules is generally taken as 1.38 Å), we conclude

(11) R. M. Noyes, *J. Am. Chem. Soc.*, **84**, 513 (1962).

(12) H. F. Halliwell and S. C. Nyburg, *Trans. Faraday Soc.*, **59**, 1126 (1963).

(13) M. S. B. Munson, *J. Am. Chem. Soc.*, **87**, 2332 (1965).

(14) M. Born, *Z. Physik*, **1**, 45 (1920).

(15) F. Basolo and R. G. Pearson, "Mechanisms of Inorganic Reactions," John Wiley and Sons Inc., New York, N. Y., 1958, p. 64.

that our $\Delta H_{n-1,n}$ values are of the correct order of magnitude.^{16,17}

The magnitudes of the $\Delta H_{n-1,n}$ values can also be compared with the values for $\text{Na}^+(\text{H}_2\text{O})_n$ calculated by Garrick¹⁸ on basis of electrostatic forces. For the purpose of the comparison, we will assume that the proton clusters contains H_3O^+ as the central ion and that the radius of H_3O^+ is very similar to that of Na^+ . Garrick obtains for the processes 2 and 3 the enthalpies (kcal/mole)¹⁹ $\Delta H_2 = -104$ and $\Delta H_3 = -114$. These

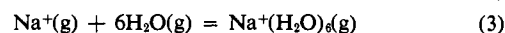
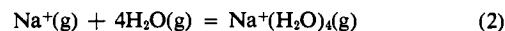

values are quite close to the corresponding enthalpies (kcal/mole): $\Delta H_{1,5} = -91$ and $\Delta H_{1,7} = 115$ for the hydrates $\text{H}^+(\text{H}_2\text{O})_5$ and $\text{H}^+(\text{H}_2\text{O})_7$ obtained in the present experiments.

The fact that the experimental value, $\Delta H_{7,8} = 10.3$ kcal/mole, is almost identical with the heat of evaporation of water does not mean that the effect of the ionic charge is negligible beyond the octahydrate. The enthalpy of evaporation depends on the radius of curvature of the water surface. For example, Dufour and Defay²⁰ estimate the heat of evaporation from a droplet with a radius of 10 Å to be 0.94 of that from a plane surface. Extending the calculation to a smaller radius of 4 Å (which was the radius of the octahydrate assumed in the previous discussion), one obtains $\Delta H_{\text{evap}}(r = 4 \text{ Å})/(\Delta H_{\text{evap}}(r = \infty)) = 0.85$, which gives 8.8 kcal/mole for the heat of evaporation of water from a neutral cluster with $r = 4$ Å. Since the calculation²⁰ depends upon the macroscopic concept of surface tension, its extension to a 4-Å radius is obviously only of orientational value. However, the calculation does indicate that a significant fraction of the $\Delta H_{7,8}$ is made up by the electrostatic interaction.

(16) The heats of hydration of complexes $\text{M}^+(\text{H}_2\text{O})_n$, where $n = 6$ or 8, have been estimated more recently by Laidler [J. S. Muirhead-Gould and K. J. Laidler, *Trans. Faraday Soc.*, **63**, 944 (1967)]. Interpolating the values obtained by Laidler one would expect a value for the $-\Delta H_{\text{sol}}(\text{H}^+(\text{H}_2\text{O})_8)$ which is around 45–55 kcal/mole. Such a value would be in better agreement with our experimental results. However, the calculations used by Laidler also involve various questionable assumptions, as do all calculations of this type.

(17) The enthalpy change considered by us has gaseous protons at very low pressure and liquid water as initial state and hydrated protons at infinite dilution as final state, while the absolute heat of hydration of the proton should involve gaseous protons at unit fugacity and liquid water as initial state and hydrogen ion solution at unit activity as final state. However, the literature value for the heat of hydration of the proton is uncertain by at least a few kilocalories. This uncertainty is larger than the enthalpy difference between the defined change and the change selected by us.

(18) F. J. Garrick, *Phil. Mag.*, **9**, 131 (1930); **10**, 76 (1930).

(19) The calculations of Garrick,¹⁸ as all calculations of electrostatic attraction between charges and dipoles, give the change of potential energy of a system of particles. In comparing such energies with thermodynamic quantities, one might ask whether they correspond to ΔH^\ddagger , ΔG , or ΔU (internal energy). Muirhead-Gould and Laidler in a recent paper¹⁶ have assumed that the potential energy changes correspond to the (Gibbs) free energy. However, since in such calculations the dipoles, charges, and molecules are assumed initially and finally at rest and devoid of any thermal motion, the process must be assumed to proceed at absolute zero where the enthalpy and free energy change are identical. A proper evaluation of the free energy or enthalpy change at temperature T should involve the cycle: cooling the educt gases to 0°K, combining them (energy change of reaction equals potential energy change), and then heating the products back to T . Assuming that the heat capacities of the educts and products are not too different, one would find that ΔH_T and ΔU_T are not too different from the calculated potential energy change. Also ΔH_T and ΔU_T will not be strongly dependent on T and will be essentially pressure independent. This will not be the case for ΔG_T . The calculated potential energies are therefore to be associated with ΔH or ΔU .

(20) L. Dufour and R. Defay, "Thermodynamics of Clouds," Academic Press Inc., New York, N. Y., 1963, p. 86.

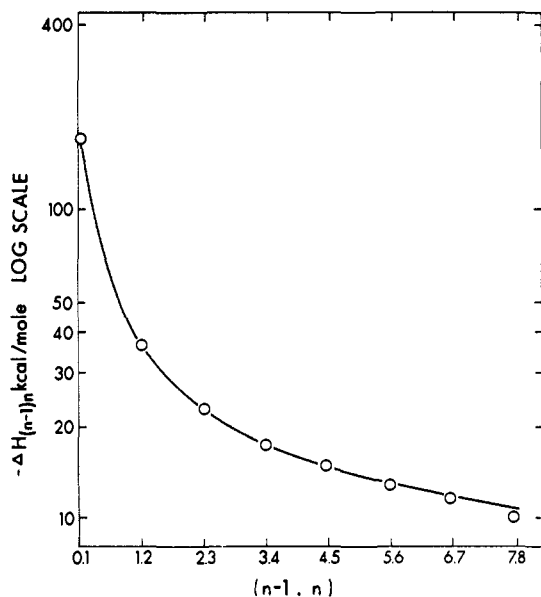

Figure 7. Logarithmic plot of $\Delta H_{n-1,n}$ vs. $n-1, n$ which allows a larger spread of values to be accommodated. Continuous extrapolation of data to $\Delta H_{0,1}$ which is the negative proton affinity of water suggests that, at least for small n , clusters are of the type $H^+(H_2O)_n$ where all water molecules are equivalent.

It is easy to show that the experimental entropy values $\Delta S_{n-1,n}$ (Table I) are of the right order of magnitude. The reaction $(n-1, n)$ is a condensation reaction and thus accompanied by a large entropy loss. The predominant term is due to loss of translational entropy which is readily calculated from the Sackur-Tetrode equation and lies in the range 30–35 eu for the reactions under discussion. The rotational and translational entropy changes depend on assumed structure. However, in general these terms are small. Also, some cancellation of rotational entropy loss with vibrational entropy gain occurs. Our values which range from 33 to 27 eu are thus in the right range.

It was hoped that the availability of the detailed $\Delta H_{n-1,n}$ and $\Delta S_{n-1,n}$ values would allow some conclusions to be made on the structure of the hydrate clusters. In order to accommodate a wide range of values, we have plotted in Figure 7 $\Delta H_{n-1,n}$ on a logarithmic scale. Included is the literature value¹³ for the reaction 0,1 (*i.e.*, negative proton affinity of water). It is interesting to note that all values including $\Delta H_{0,1}$ lie on a smooth curve. This suggests that step 0,1 is not so different in kind from steps 1,2, 2,3, etc. This in turn could mean that, for example, in the cluster containing one proton and two water molecules, the two water molecules are equally strongly bonded to the proton and thus equivalent. The notation $H^+(H_2O)_2$ would then be more appropriate than $H_3O^+H_2O$ which indicates that the proton is more strongly bonded to one oxygen such that there is a central H_3O^+ ion. It is of course not possible on the basis of the present data to decide up to what size of cluster do all water molecules remain equivalent. On general grounds it is conceivable that this could be the case up to the tetra- or even hexahydrate. Our work on the competitive solvation of the hydrogen ion by water and methanol molecules²¹

(21) P. Kebarle, R. M. Haynes, and J. G. Collins, *J. Am. Chem. Soc.*, in press.

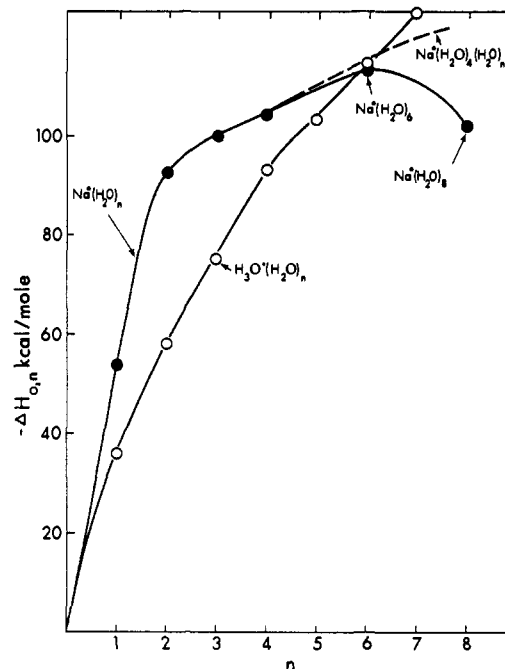

Figure 8. Plot of summed enthalpies of hydration $\Delta H_{0,n}$. The enthalpies for $Na^+(H_2O)_n$ and $Na^+(H_2O)_4(H_2O)_{n-4}$ are based on calculations by Garrick.¹⁸ The hydrogen ion data are from the present experiments. We have written $H_3O^+(H_2O)_n$ in order to facilitate comparison with sodium. The calculated sodium data illustrate that the buildup of a new shell need not show up as a discontinuity in $\Delta H_{n-1,n}$ values since calculated $Na^+(H_2O)_6$ and $Na^+(H_2O)_4(H_2O)_2$ have very similar enthalpies.

indicated that in a cluster $H^+(CH_3OH)_m(H_2O)_w$, where $m+w$ are 4, 5, or 6, all water molecules are equivalent among themselves and all methanol molecules are equivalent among themselves; *i.e.*, the proton is not more strongly attached to one particular molecule.

The relatively smooth changes of $\Delta H_{n-1,n}$ and $\Delta G_{n-1,n}$ with n (Figures 4 and 5) do not provide any clear-cut indication where an initial first shell is completed and the buildup of an outer shell begins. Off-hand one would expect that the start of a new shell would be indicated by a drop-off in the (negative) $\Delta H_{n-1,n}$ values because of the reduced attraction at larger distance from the central charge. This is, in fact, what one observes^{3,22} in the system $NH_4^+(NH_3)_n$ where the enthalpy drops off between $\Delta H_{3,4}$ and $\Delta H_{4,5}$ showing the presence of an inner four shell. We can expect a discontinuous transition in cases where the structure of the central ion and solvent molecule is such that a stable and compact inner shell is built up which forces the additional solvent molecule into an outer position. Such a behavior can be expected in the $NH_4^+(NH_3)_4$ system where the tetrahedral NH_4^+ ion and the pyramidal ammonia molecules form a compact structure which should also have good stability since the coordination number is matched to the symmetry of the central ion. One can conceive of other systems in which the transition from an inner to an outer shell does not involve a discontinuous change of ΔH (and ΔS). This will be the case where a succession of structures of similar stabilities can be taken up with increasing number of solvent molecules. An illustra-

(22) S. K. Searles and P. Kebarle, *J. Phys. Chem.*, in press.

tion that such a behavior is possible can be obtained on the basis of calculations made by Garrick¹⁸ for spherical ions and spherical solvent molecules. In Figure 8 we have plotted the enthalpies of hydration for the ion Na^+ obtained by Garrick.¹⁸ Garrick's calculations deal only with first shell energies and are based on the following interactions: electrostatic attraction of charge with permanent and induced dipole of molecules, electrostatic repulsion of dipoles of molecules, and repulsion between electronic charge clouds of central ion-molecule(s) and molecule-molecule. The radius between the center of the ion and the centers of the symmetrically disposed ligands was obtained by minimization of the total energy. We see in Figure 8 that $-\Delta H_{0,1}$ is large since the only opposing force is the repulsion between the ion and the dipole charge clouds. $-\Delta H_{1,2}$ is only slightly smaller, the only significant change being the dipole-dipole repulsion across the diameter of the complex. $-\Delta H_{n-1,n}$ decreases faster with further growth because of the increasing importance of the dipole-dipole and molecule-molecule repulsions. Finally these repulsions become so large that $\Delta H_{6,8}$ becomes positive. It is interesting now to examine what happens if one begins, at some point, the buildup of an outer shell. Obviously an outer shell starting after six molecules will lead to a more stable octahydrate $\text{Na}^+(\text{H}_2\text{O})_6(\text{H}_2\text{O})_2$, but the calculations show that also $\text{Na}^+(\text{H}_2\text{O})_4(\text{H}_2\text{O})_2$ might be more stable than $\text{Na}^+(\text{H}_2\text{O})_6$ (see dashed line Figure 8). Since the above calculations are all of an approximate nature, it is not important whether the predicted stability of the one or other hydrate is higher. However, the calculations illustrate one important point well, namely, that a discontinuous change of $\Delta H_{n-1,n}$ need not be present when a new shell is started. Crowding in the inner

shell reduces the last inner-shell enthalpies so that they extrapolate continuously into the outer-shell enthalpies. We come to the conclusion that in the region, where $-\Delta H_{n-1,n}$ values become small, crowding of the first shell or transition to an outer shell occurs. Considering now the experimental $\Delta H_{n-1,n}$ and $\Delta(\Delta H_{n-1,n})$ and corresponding free-energy changes shown in Figures 4 and 5, we notice that a considerable decrease of the negative $\Delta H_{n-1,n}$, and $\Delta G_{n-1,n}$ is observed between 3,4 and 4,5. We may therefore conclude that either considerable crowding or a new shell is started beyond four water molecules. In the interpretation of the $\Delta S_{n-1,n}$ values, one might assume that the start of a new shell would be indicated by a drop of the (negative) $\Delta S_{n-1,n}$ due to the larger freedom of the outer molecule. If this is so, our data would not indicate a new shell. Instead, crowding occurs in the step 4,5 since $-\Delta S_{4,5}$ is larger than $-\Delta S_{3,4}$. However, it must be pointed out that the ΔS values are obtained from the difference of two large terms $[(\Delta H/T) - (\Delta G/T)]$ and are thus subject to a combined experimental error. Therefore we cannot be certain that the increase at the $-\Delta S_{4,5}$ is real. Also the expectation that the $-\Delta S$ decreases greatly with change of shell might be naive. The incorporation of a molecule in an outer position might impose constraints on the inner molecules and also lead to a considerable reorganization of the total complex. In such a case the ΔS outer molecule might not be too different from the ΔS values of the last inner molecules.

We feel that the interpretation of the $\Delta H_{n-1,n}$ and $\Delta S_{n-1,n}$ changes will become more meaningful as data on a larger number of ions become available. For this purpose experiments on the hydration of spherical ions (Na^+ , K^+) and structured ions (NH_4^+) are presently under way in this laboratory.